

Butterfly Valve Technical Information

Installation Guide

1. This Butterfly Valve is bi-directional and may be installed in either direction.
2. Install this valve between any ANSI Class 125 or 150 flange. Cast iron, bronze, plastic or steel flanges may be used. No flange gaskets are required.
3. The stem can be installed in any position, but if a choice of stem positions exists, good practice dictates that the valve be installed with the stem horizontal. This will minimize liner wear by distributing stem and disc weight evenly.
4. Valves should be installed with the disc in the closed or almost closed position. This will prevent damage to the disc sealing edge.
5. Before any flange bolts are tightened, valves should be centered within the flanges and then carefully opened to assure free, unobstructed disc movement. Disc interference may result when valves are installed in pipelines having smaller than normal inside diameters, such as heavy wall pipe, plastic lined pipe, or as cast flanges. Suitable corrective measures must be taken to remove these obstructions, such as taper boring the pipe or installing a spacer.
6. After proper operation has been verified, tighten all bolts using the crossover method. Recommended tightening torques pattern is listed below.

Flange Size	Recommended Min. Bolt Torque	Flange Size	Recommended Min. Bolt Torque
2 - 4"	20 - 30 ft. lbs.	18 - 20"	150 - 210 ft. lbs.
6 - 8"	33 - 50 ft. lbs.	24 - 30"	215 - 300 ft. lbs.
10"	53 - 75 ft. lbs.	36"	300 - 375 ft. lbs.
12"	80 - 110 ft. lbs.	42 - 48"	350 - 425 ft. lbs.
14- 16"	140 - 200 ft. lbs.		

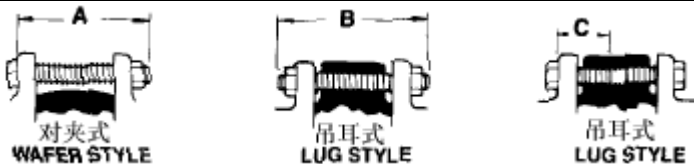
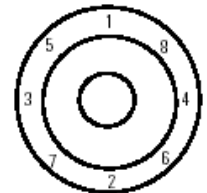

7. Interference may also occur when butterfly valves are bolted directly to the outlet flange of a swing check, silent check, or reducing flange. Check valve and butterfly valve combinations are very popular; normally a short spool piece

is required between the valves.

Caution

1. Class 250 cast iron and Class 300 steel flanges **can not** be used on these valves.
2. Rubber faced or mechanical flanges are **not** recommended.
3. This valve is **not recommended** for steam service.
4. Valves should **not** be assembled to the flanges and then welded into the piping system.

5. Lever-lock handles are **not** recommended for use on 8" and larger valves.
6. Do not install EPDM liner in compressed air lines.

Caps crew and Bolt Data

Valve Size	Diameter	Number		Bolt Length "A" Rounded Length	Stud Length "B" Rounded Length	Cap Screw Length "C" Rounded Length
		Machine & Stud	Cap Screw			
2"	0.625	4	8	4.00	5.00	1.25
2 1/2"	0.625	4	8	4.25	5.25	1.50
3"	0.625	4	8	4.50	5.25	1.50
4"	0.625	8	16	5.00	6.00	1.75
5"	0.750	8	16	5.50	6.50	1.75
6"	0.750	8	16	5.50	6.75	2.00
8"	0.750	8	16	6.00	7.00	2.25
10"	0.875	12	24	6.75	8.00	2.25
12"	0.875	12	24	7.00	8.25	2.50
14"	1.000	12	24	7.50	8.50	2.75
16"	1.000	16	32	8.00	9.50	3.25
18"	1.125	16	32	9.00	10.50	3.50
20"	1.125	20	40	9.50	11.00	4.00
24"	1.250	20	40	11.00	12.50	4.75
30"	1.250	-	56	-	-	3.50
36"	1.500	-	64	-	-	4.00
42"	1.500	-	72	-	-	4.50
48"	1.500	-	88	-	-	4.75

Notes: All valves are suitable for installation with pipe flanges conforming to ANSI B-16.1 (Class 125 iron flanges) and ANSI B-16.5 (Class 150 steel flanges).

All screw threads are according to ANSI B-1.1 coarse thread.

Butterfly Valve Technical Information (2)

Gear Operator Installation Instructions (2" thru 18" 1000/2000/3000/4000/5000 series)

<http://www.eninevalve.com>

E-mail: info@eninevalve.com

INSTALLATION

- a. Install hand wheel (1) onto gear operator shaft and secure with pin (2). (If not already attached)
- b. Turn the hand wheel (1) counter-clockwise until in full OPEN position.
- c. Turn valve stem (5) until valve is in full OPEN position.
- d. Assure both mounting base of gear operator (3) and valve top flange (6) is clean and dry.
- e. Insert adapter bushing into gear operator (3) bore. (If necessary)
- f. Align adapter bushing or gear operator (3) bore with valve stem (5). Note that on Fire Protection models adaptor bushings may differ from illustration.
- g. Secure gear operator (3) to valve top flange (6) using a minimum of two supplied fasteners (7 & 8).
- h. Install flag and secure with Allen screw. (Fire Protection gear operators only)
- i. Rotate hand wheel from full OPEN to full SHUT positions several times to assure proper operation. See Stop Adjustment Procedure if alignment adjustment is necessary.

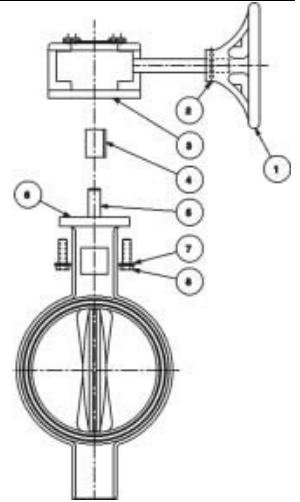

Tools Required		
(UL/FM) Fire Protection (UL/FM)	2" — 8"	9/16" hex wrench & 1/8" hex allen wrench
	10" — 12"	3/4" hex wrench and 1/8" hex allen wrench
Commercial	2" — 8"	9/16" hex wrench
	10" — 14"	3/4" hex wrench
	16" — 18"	1-1/8" hex wrench

For Fire Protection, gear operators, it is critical to use only key (8) supplied with gear operator to conform to UL, FM, and ULC specifications.

NOTE: Connection of gear operator to valve stem varies depending on gear operator model, size, and style. The adapter bushing and key may be different from illustration shown.

MAINTENANCE AND REPAIR

All gear operators are lubricated for life at assembly and should not require service. In the event of a gear operator suffering damage or excessive wear, it is suggested that the complete gear operator be replaced. Only the hand wheel (1), pin (2), and some adapter bushings (4) are available for repair parts.

NOTE: The gear operators are shipped from the factory, "pre-set" for mounting to valves that are in the closed position

Butterfly Valve Technical Information (3)

2000/3000 Series Technical Information

Valve with Gear Mounted

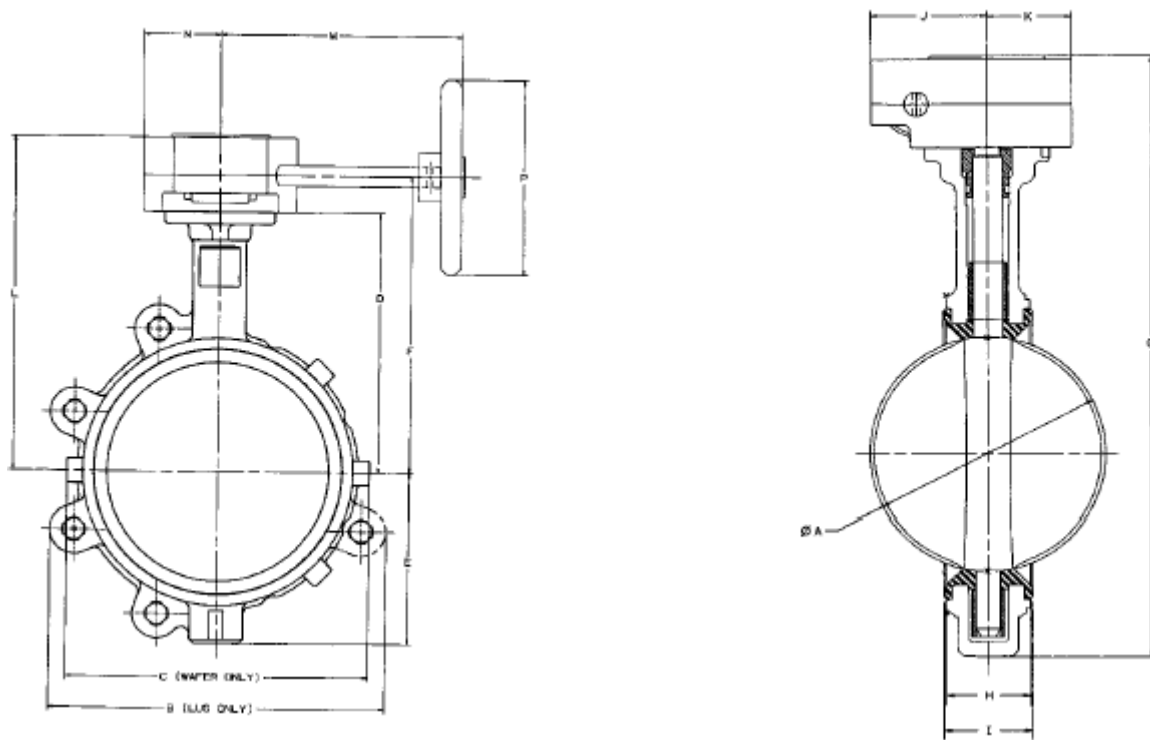

Typical LD/WD2000-5

DIMENSIONS — WEIGHTS

Size	A	B (Lug)	C (Wafer)	D	E	F	G
2"	2.53	4.62	4.88	5.38	2.88	6.51	10.64
2 1/2"	2.90	5.62	5.62	5.88	3.25	7.01	11.51
3"	3.17	6.12	6.12	6.12	3.38	7.25	11.88
4"	4.17	8.25	7.00	6.88	4.00	8.01	13.26
5"	5.17	9.38	8.25	7.38	4.75	8.51	14.51
6"	6.17	10.25	9.25	8.00	5.25	9.13	15.63
8"	8.17	12.38	11.62	9.25	6.50	10.38	18.13
10"	10.17	15.50	14.25	10.50	8.00	11.63	20.88
12"	12.17	18.25	16.75	12.00	9.25	13.13	23.63

Size	H (Metal)	I (Rubber)	J	K	L	M	N	P
2"	1.68	1.81	2.91	2.13	7.87	7.64	2.12	5.91
2½"	1.81	1.94	2.91	2.13	8.37	7.64	2.12	5.91
3"	1.81	1.94	2.91	2.13	8.62	7.64	2.12	5.91
4"	2.06	2.19	2.91	2.13	9.37	7.64	2.12	5.91
5"	2.19	2.31	2.91	2.13	9.87	7.64	2.12	5.91
6"	2.19	2.31	2.91	2.13	10.50	7.64	2.12	5.91
8"	2.38	2.50	2.91	2.13	11.75	9.53	2.12	9.84
10"	2.69	2.81	3.90	3.03	13.46	11.54	3.03	9.84
12"	3.00	3.12	3.90	3.03	14.96	11.54	3.03	9.84

Butterfly Valve Technical Information (4)

Resilient Liner Materials

EPDM – EPDM is a terpolymer elastomer made from ethylene-propylene diene monomer. EPDM has good abrasion and tear resistance and offers excellent chemical resistance to a variety of acids and alkalines. It is susceptible to attack by oils and is not recommended for applications involving petroleum oils, strong acids, or strong alkalines. EPDM should not be used on compressed air lines. It has exceptionally good weather aging and ozone resistance. It is fairly good in ketones and alcohols.

BUNA-N (Nitrile) (NBR) – Buna-N is a general purpose oil resistant polymer known as nitrile rubber. Nitrile is a copolymer of butadiene and acrylonitrile. Buna-N has good solvent, oil, water and hydraulic fluid resistance. It displays good compression set, abrasion resistance and tensile strength. Buna-N should not be used in highly polar solvents such as acetone and methyl ethyl ketone, nor should it be used in chlorinated hydrocarbons, ozone or nitro hydrocarbons. Some aviation fuels may not be compatible.

Fluoroelastomer (VITON*) (FKM) – Fluoroelastomers are inherently compatible with a broad spectrum of chemicals. Because of this extensive chemical compatibility which spans considerable concentration and temperature ranges, fluoroelastomers have gained wide acceptance as a material of construction for butterfly valve O-rings and seats. Fluoroelastomer can be used in most applications involving mineral acids, salt solutions, chlorinated hydrocarbons and petroleum oils. It is particularly good in hydrocarbon service. FKM is not recommended for use in high temperature water.

*Trademark of E.I. Dupont Co.

Liner Temperature Ratings

Proprietary compound formulas are used for each of the elastomers to provide the right combination of seat

Liner Material	Temperature
EPDM** Nitrile (Buna-N) Fluoroelastomer	-29°C 至 +121°C
	-20°F to + 250°F
	-29°C 至 +82°C
	-20°F to + 180°F
	-29°C 至 148°C
	-20°F to + 300°F

compression, abrasion resistance, and chemical resistance to match your application. Elastomeric seat materials are not suitable for steam service.

** EPDM is rated at 250°F intermittent service and 225°F continuous service.

Butterfly Valve Technical Information (5)

Metals Used in Valves & Fittings

Aluminum—A non-ferrous metal, very lightweight, approximately one-third as much as steel. Aluminum exhibits excellent atmospheric corrosion resistance, but can be very reactive with other metals. In valves, aluminum is mainly used as an exterior trim component such as a handwheel or identification tag.

Copper—Among the most important properties of wrought copper materials are their thermal and electrical conductivity, corrosion resistance, wear resistance, and ductility. Wrought copper performs well in high temperature applications and is easily joined by soldering or brazing. Wrought copper is exclusively used for fittings.

Bronze—One of the first alloys developed in the bronze age is generally accepted as the industry standard for pressure rated bronze valves and fittings. Bronze has a higher strength than pure copper, is easily cast, has improved machinability, and is very easily joined by soldering or brazing. Bronze is very resistant to pitting corrosion, with general resistance to most chemicals less than that of pure copper.

Silicon Bronze—Has the ductility of copper but much more strength. Silicon bronze has equal or greater corrosion resistance to that of copper. Commonly used as stem material in pressure-rated valves, silicon bronze has greater resistance to stress corrosion cracking than common brasses.

Aluminum Bronze—The most widely accepted disc material used in butterfly valves, aluminum bronze is heat treatable and has the strength of steel. Formation of an aluminum oxide layer on exposed surfaces makes this metal very corrosion resistant. Not recommended for high pH wet systems.

Brass—Generally good corrosion resistance. Susceptible to de-zincification in specific applications; excellent machinability. Primary uses for wrought brass are for ball valve stems and balls, and iron valve stems. A forging grade of brass is used in ball valve bodies and end pieces.

Gray Iron—An alloy of iron, carbon and silicon; easily cast; good pressure tightness in the as-cast condition. Gray iron has excellent dampening properties and is easily machined. It is standard material for bodies and bonnets of Class 125 and 250 iron body valves. Gray iron has corrosion resistance that is improved over steel in certain environments.

Ductile Iron—Has composition similar to gray iron. Special treatment modifies metallurgical structure which yields higher mechanical properties; some grades are heat treated to improve ductility. Ductile iron has the

strength properties of steel using similar casting techniques to that of gray iron.

Carbon Steel—Very good mechanical properties; good resistance to stress corrosion and sulfides. Carbon steel has high and low temperature strength, is very tough and has excellent fatigue strength. Mainly used in gate, globe, and check valves for applications up to 850°F, and in one-, two-, and three-piece ball valves.

3% Nickel Iron—Improved corrosion resistance over gray and ductile iron. Higher temperature corrosion resistance and mechanical properties. Very resistant to oxidizing atmospheres.

Nickel-Plated Ductile Iron—Nickel coatings have received wide acceptance for use in chemical processing. These coatings have very high tensile strength, 50 to 225 ksi. To some extent, the hardness of a material is indicative of its resistance to abrasion and wear characteristics. Nickel plating is widely specified as a disc coating for butterfly valves.

400 Series Stainless Steel—An alloy of iron, carbon, and chromium. This stainless is normally magnetic due to its martensitic structure and iron-content. 400 series stainless steel is resistant to high temperature oxidation and has improved physical and mechanical properties over carbon steel. Most 400 series stainless steels are heat-treatable. The most common applications in valves are, for stem material in butterfly valves, and backseat bushings and wedges in cast steel valves.

316 Stainless Steel—An alloy of iron, carbon, nickel, and chromium. A non-magnetic stainless steel with more ductility than 400SS. Austenitic in structure, 316 stainless steel has very good corrosion resistance to a wide range of environments, is not susceptible to stress corrosion cracking and is not affected by heat treatment. Most common uses in valves are: stem, body and ball materials.

17-4 PH Stainless Steel*—Is a martensitic precipitation/age hardening stainless steel offering high strength and hardness. 17.4 PH withstands corrosive attack better than any of the 400 series stainless steels and in most conditions its corrosion resistance closely approaches that of 300 series stainless steel. 17.4 PH is primarily used as a stem material for butterfly and ball valves.

Alloy 20Cb-3*—This alloy has higher amounts of nickel and chromium than 300 series stainless steel and with the addition of columbium, this alloy retards stress corrosion cracking and has improved resistance to sulfuric acid. Alloy 20 finds wide use in all phases of chemical processing. Commonly used as interior trim on butterfly valves.

Monel*—Is a nickel-copper alloy used primarily as interior trim on butterfly and ball valves. One of the most specified materials for corrosion resistance to sea and salt water. Monel is also very resistant to strong caustic solutions.

Stellite*—Cobalt base alloy, one of the best all-purpose hard facing alloys. Very resistant to heat, abrasion, corrosion, impact, galling, oxidation, thermal shock and erosion. Stellite takes a high polish and is used in steel valve seat rings. Normally applied with transfer plasma-arc; Stellite hardness is not affected by heat treatment.

Hastelloy C*—A high nickel-chromium molybdenum alloy which has outstanding resistance to a wide variety of chemical process environments including strong oxidizers such as wet chlorine, chlorine gas, and ferric chloride. Hastelloy C is also resistant to nitric, hydrochloric, and sulfuric acids at moderate temperatures.

Butterfly Valve Technical Information (6)

Torque Data

LD/WD 2000 Series Torque Data			
Size	100 PSI	200 PSI	250 PSI
2"	140	180	195
2½"	190	235	255
3"	250	300	325
4"	430	530	580
5"	590	790	845
6"	795	1,035	1,115
8"	1,850	2,350	2,600
10"	2,350	2,900	3,125
12"	3,875	5,390	6,145

LD/WD 1000 Series Torque Data				
Size	50 PSI	75 PSI	100 PSI	
14"	-	3,837	-	4,870
16"	-	5,003	-	6,685
18"	-	6,567	-	8,958
20"	-	8,540	-	11,950
24"	-	13,220	-	18,680
30"	28,320	29,782	30,864	33,336
36"	40,624	41,875	43,480	46,528
42"	69,744	72,076	74,632	79,864
48"	96,648	100,520	103,840	111,112

N200 Series Torque Data		
Size	100 PSI	200 PSI
2"	120	220
2½"	130	320
3"	180	480
4"	280	820
5"	360	1,162
6"	600	1,560

Butterfly Valve Torque Data			
<p>Torque is the rotary effort required to operate a valve. This turning force in a butterfly valve is determined by three factors. (1) Friction of the disc to seat for sealing (2) Bearing friction (3) Dynamic torque.</p> <p>Breakaway Torque is the total of the torques resulting from bearing friction and seat/disc interference friction at a given pressure differential. This value is normally the highest required torque to operate a valve, and is used in sizing actuators. The values listed at the left are based on performance tests and include a safety factor. The torques listed is valid for water and lubricating fluids at ambient temperature.</p> <p>Butterfly valves, sizes 8" and larger, when used on liquids, show a marked increase in dynamic torque which tends to close the valve. For this reason, gear operated or actuated valves are recommended.</p> <p>Torque listed for EPDM. When calculating torques for Buna-N, or Fluoroelastomer multiply listed torque by 1.25. Consult factory for dry service valves.</p>			
FC/FD27*5/57*5 GD4765/4775 Torque Data			
Size	100 PSI	200 PSI	300 PSI
2"	48	67	83
2½"	48	67	83
3"	100	134	168
4"	185	251	317
5"	294	410	499
6"	520	705	890
8"	1,070	1,495	1,798
10"	1,550	2,214	2,654
12"	2,150	3,024	3,662

8"	1,100	2,890
10"	2,040	5,270
12"	4,500	8,050

N150 Series Torque Data

Size	100 PSI	200 PSI
14	4,125	4,870
16	5,590	6,685
18	7,354	8,958
20	9,670	11,950
24	14,860	18,680

Note: Torque Data shown is for general service (clean water, ambient temperatures).